

SIDE VIEW OF FRAMING

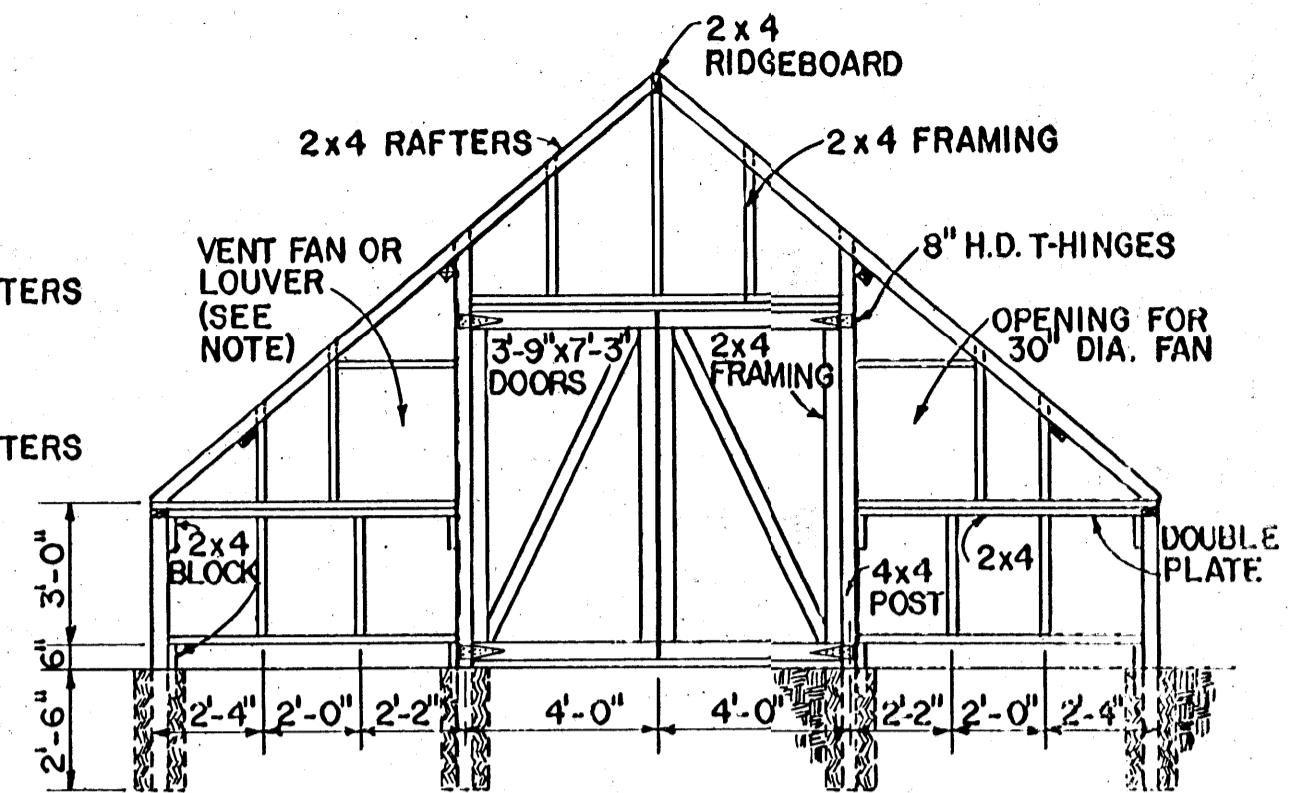

END VIEW OF FRAMING

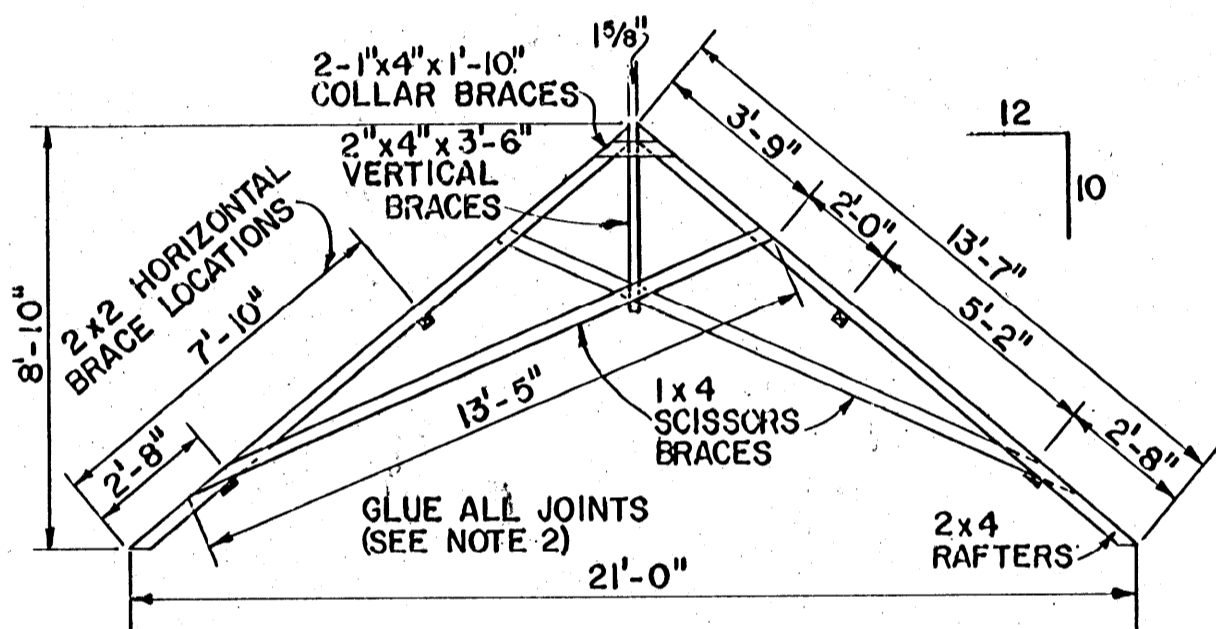

RAFTER DETAIL

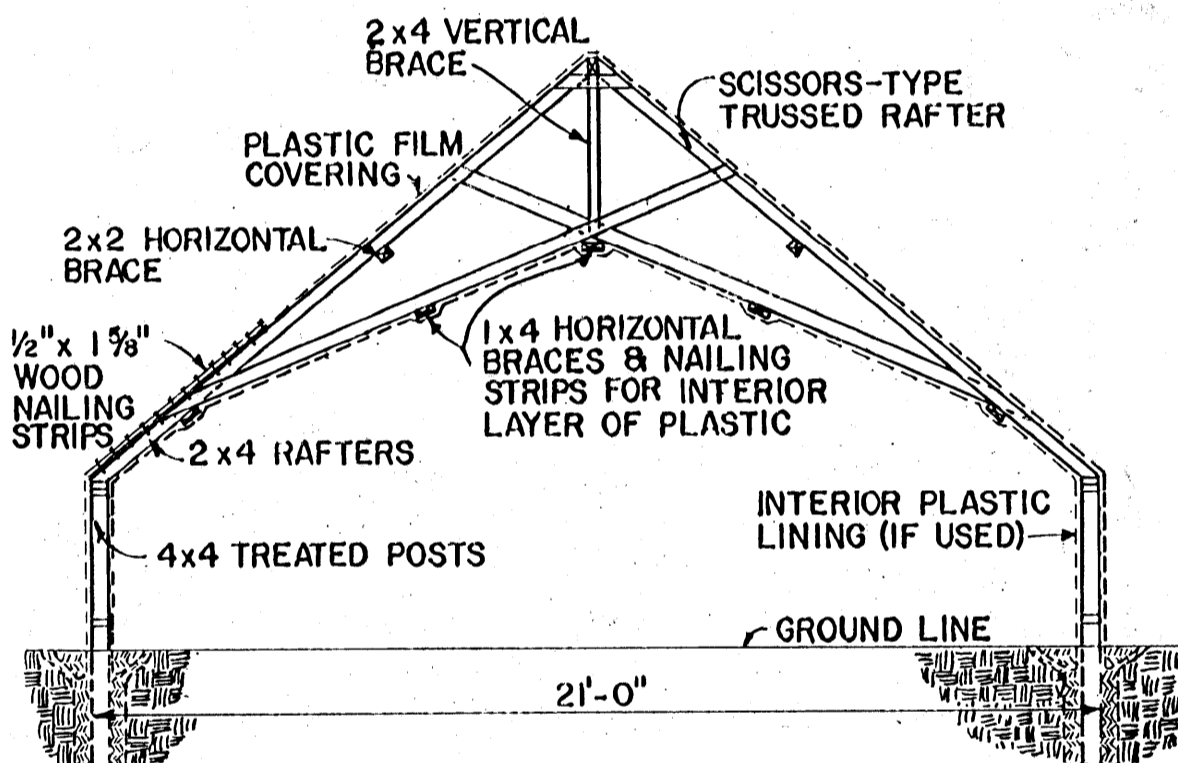

CROSS SECTION

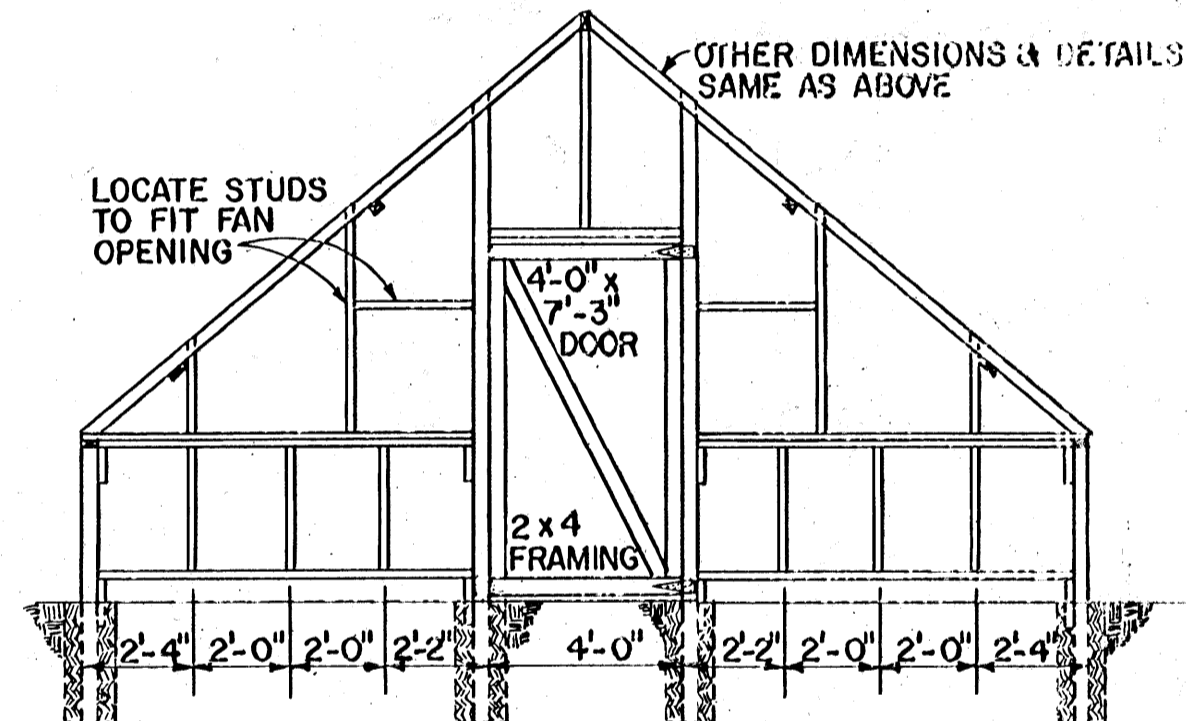

ALTERNATE END VIEW

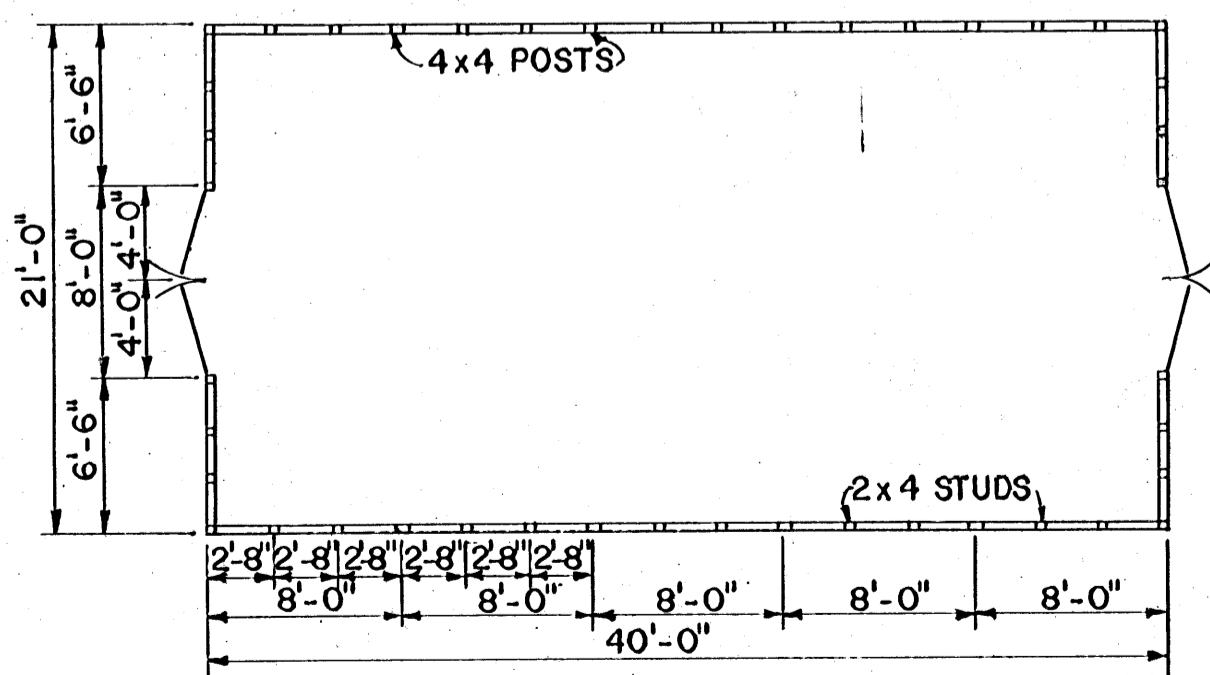

FLOOR PLAN

SCALE - 1/8" = 1'-0"
12' 0" 1' 2' 4' 6' 8'

NOTES:

1. IF 30" FAN FRAMES ARE TOO LARGE FOR OPENING PROVIDED, LOWER PLATE AND MOVE STUD AS REQUIRED, OR USE THREE 24" FANS AND PLACE ONE IN GABLE OVER DOORS, OR MAKE DOORS NARROWER. (ALSO SEE ALTERNATE END VIEW OF FRAMING.)
2. ALL JOINTS GLUED (USE A GOOD WATERPROOF WOOD GLUE) AND NAILED WITH 6-PENNY GALVANIZED SERRATED NAILS.
3. CONSULT LOCAL HEALTH AND BUILDING CODE AUTHORITIES BEFORE STARTING CONSTRUCTION.

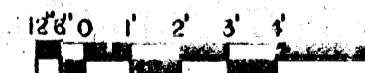

SCALE: 1/4" = 1'-0" UNLESS OTHERWISE NOTED.

COOPERATIVE EXTENSION WORK IN
AGRICULTURE AND HOME ECONOMICS
STATE OF MISSISSIPPI
MISSISSIPPI STATE UNIVERSITY
AND
UNITED STATES DEPARTMENT OF AGRICULTURE COOPERATING

**GREENHOUSE
SCISSORS TRUSS**

VA. '78 6311 SHEET 1 OF 1